



**BakerSeries Reversible Table Top Dough Sheeter**

Item No. \_\_\_\_\_  
 Project \_\_\_\_\_  
 Quantity \_\_\_\_\_

**MODEL: TTS - Series**



Model TTS-20 shown

**PRODUCTION CAPACITY GUIDE**

Capacity / Model	TTS-20
Belt Width	20"
Overall Length	57.50"

**Short Bid Specification:**

Dough Sheeter shall be a **LBC Bakery Equipment Model TTS-20**, table-top, 3-phase 208 / 240 VAC reversible dough sheeter. Sheeter shall be equipped with 6' power cored with twist lock plug. Feed belt shall be seamless, non-absorbing Rayon. Feed tables shall be aluminum and shall be foldable for storage and shall include attached baton (rolling pin). Base and all attached surfaces shall be stainless steel. Head assembly shall be polished aluminum. Controls shall include infinitely adjustable roller pressure, adjustable final roller height stop position, On/Off switch, safety interlock switches at the in-feed guards and motor direction foot controls. Dry type clutch drive shall automatically overdrive out-feed belt by 20% in both directions. Dough sheeter shall be ETL listed or equivalent for Safety and Sanitation.

**Construction Features**

- Non-absorbant Rayon® Belts
- Stainless steel Attachments
- Non-painted construction
- Polished Aluminum head assembly
- Nylon rollers
- Stainless steel in-feed hand and finger guard
- Aluminum folding feed tables
- Baton (Rolling Pin) with floating and park position bracket
- Table top design

**Performance Features**

- 1 HP 3 Phase drive motor
- Full reversing motor operation
- Dry clutch feed belt drive
- Automatic belt speed compensation in both directions
- 20% overdrive on outfeed belt

**Controls Features**

- Infinitely adjustable roller height
- Pistol grip roller adjustment with release lock
- Adjustable final roller position stop
- Foot control switch (Left/Right)
- Rotary On/Off switch



Meets UL 763 and NSF-8 Standards

**STANDARD PRODUCT WARRANTY**

One-Year Parts and 90 Days Labor (contiguous US Including Alaska and Hawaii, Canada)

Sheet Number TTS (rev 06/06)



**BakerSeries Reversible Table Top Dough Sheeter      MODEL: TTS - Series**

**INSTALLATION REQUIREMENT:** 208-240 VAC, 50-60 Hz. 3Phase, 20 Amps, NEMA L15-20 Receptacle

**OPTIONS & ACCESSORIES:** Baton (Rolling Pin)

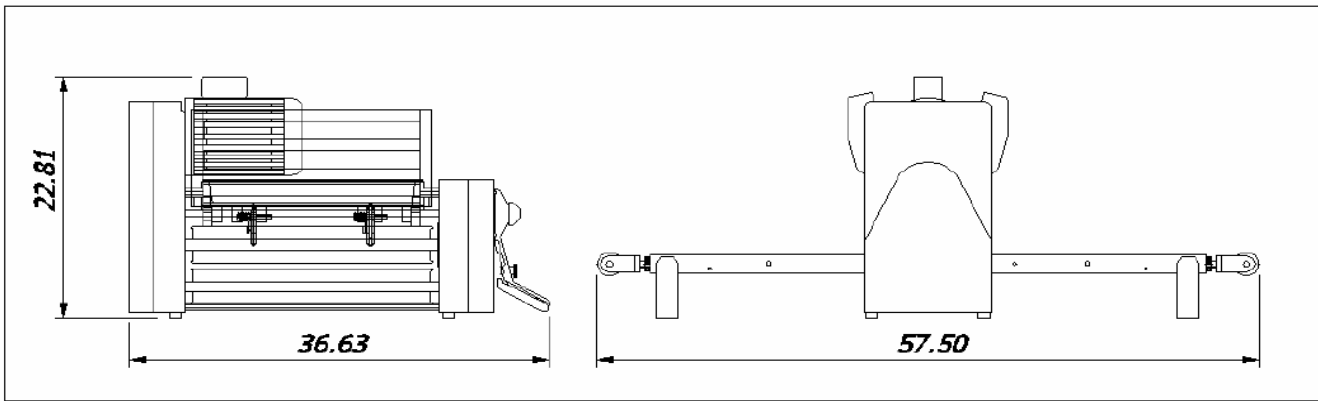

Model	Dimensions Height x Width x Depth		Clearance from Combustibles		Weight		Freight Class
	Flat	Folded	Sides and Back	Top	Actual	Shipping	
TTS-20	23 x 37 x 58	40x 37 x 30	0"	0"	350	400	85

Electrical Specifications			
Voltage	Phase	TTS-20	
		HP	Amps
208 VAC 60Hz	3	1	12
240 VAC 60Hz	3	1	12

Sheet Number TTS (rev 06/06)